

Photovoltaic Cells

Energy produced by the sun is called *solar energy*. It is produced during nuclear reactions that take place throughout the volume of the sun. The energy travels to Earth in the form of light.

Photovoltaic (PV) cells, or solar cells, change the light energy to electrical energy that can be used to power calculators, cars or even satellites. A photovoltaic cell is usually made of a semiconducting material such as silicon. When light strikes the cell, it provides enough energy to move electrons through the cell producing an electric current. A single photovoltaic cell is approximately the size of a fingernail and puts out a very small current when struck by the light. Objects requiring higher currents to operate can be powered by wiring large numbers of photovoltaic cells together.

Items powered by solar energy are said to be using *solar power*. Streetlights that must operate in the dark store the energy in a battery while the sun is shining and then use the energy at night. Scientists working in remote places rely on solar power to operate their computers and equipment. What things can you think of that are powered by solar energy?

In Part I of this experiment, you will measure the current and voltage produced by a photovoltaic cell when exposed to sunlight. You will calculate the power output of the cell using the relationship

$$P = VI$$

Power = voltage \times current

You will also calculate the efficiency of the photovoltaic cell when converting the energy from the sun into electrical energy.

In Part II the relationship between the wavelength of the light striking the photovoltaic cell and power output will be investigated.

OBJECTIVES

In this experiment, you will

- Use a Current Probe to measure current output.
- Use a Voltage Probe to measure voltage output.
- Use a Light Sensor to measure light intensity.
- Calculate power output.
- Calculate efficiency.
- Investigate the relationship between wavelength of light and power output.

MATERIALS

computer
Vernier computer interface
Logger *Pro*
Current Probe
Voltage Probe
Light Sensor

photovoltaic cell
wire leads with alligator clips
100 Ω resistor
blue, green, and red filters
sunshine
ruler

PRE-LAB QUESTIONS

1. In Part I of this experiment, you will determine the efficiency of the photovoltaic cell. A cell that converts all of the light energy into electrical energy is said to be 100% efficient. What do you predict to be the efficiency of the cell? Express your answer in percent form with 100% representing that all of the sunlight is converted to electrical energy and 0% representing that none of the sunlight is converted to electrical energy.
2. In Part II of this experiment, you will investigate the relationship between the wavelength of light striking the photovoltaic cell and the power output of the cell. Do you think that the wavelength of light will affect the power output? If so, which wavelength – red, blue, or green – will produce the highest power output?

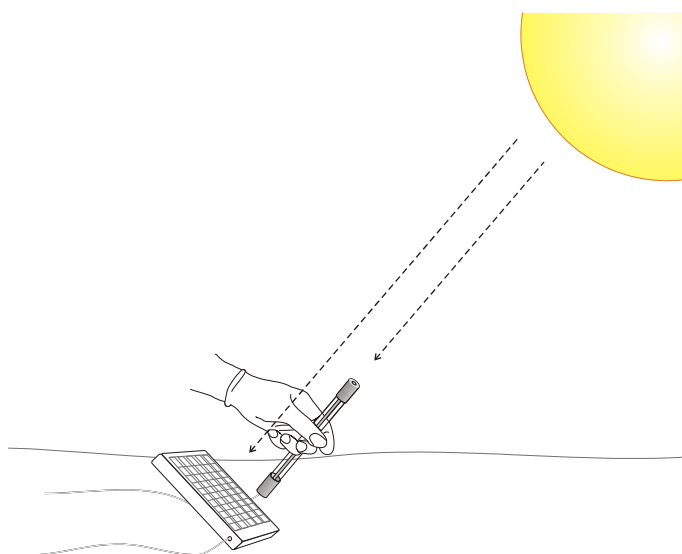



Figure 1

PROCEDURE

Part I Determining Power Output

1. Connect the Current Probe to Channel 1, the Voltage Probe into Channel 2, and the Light Sensor to Channel 3 of the Vernier computer interface. Set the Light Sensor to the 0–150,000 lux range.
2. Open the file “25 Photovoltaic Cells” in the *Agricultural Science with Vernier* folder.
3. Connect together the two voltage leads (red and black) of the Voltage Probe. Click then zero both Current and Potential. This sets the zero for both probes with no current flowing and with no voltage applied.
4. Connect the series circuit shown in Figure 2. The red terminal of the Current Probe should be toward the + terminal of the photovoltaic cell. Look at the bottom of the PV cell to determine polarity. Connect the red lead of the Voltage probe to the wire coming from the + terminal of the PV cell and the black lead to the wire leading to the – terminal.

5. Tilt the PV cell toward the sun. Hold the Light Sensor at the same angle. The light intensity reading is displayed in the Illumination meter. Record this value in the data table.
6. Click  to begin data collection.
7. When data collection is complete, click on the Current graph to make it active. Click the Statistics button, , to display a Statistics box for the Current Probe. Record the mean current reading in the data table.

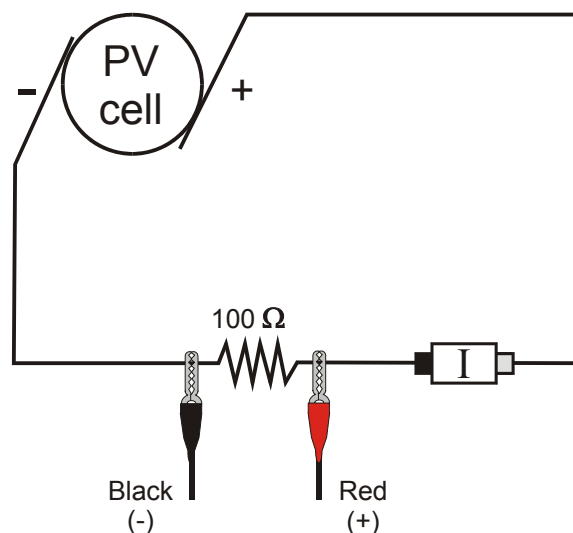



Figure 2

8. Click on the Voltage graph. Click the Statistics button, , to display a Statistics box for the Voltage Probe. Record the mean voltage reading in the data table.
9. Repeat steps 5–8 for two more trials. Keep the tilt of the PV cell and Light Sensor the same in all three trials.

Part II Effect of Wavelength

10. Repeat Steps 5–8 once more and record the mean values for current and voltage and the illumination value in the data table for Part II.
11. Place a blue filter over the tip of the Light Sensor. Tilt the Light Sensor toward the sun. Record the light intensity in the data table. Place the blue filter over the PV cell and tilt the PV cell toward the sun. Repeat Steps 6–8. Record the mean values for current and voltage in the data table.
12. Repeat Step 11, first with a red filter, and then with a green filter.

DATA

Part I Determining Power Output

	Current (A)	Voltage (V)	Illumination (lux)
Trial 1			
Trial 2			
Trial 3			
Average			

Instructions for completing the following table can be found in the Processing the Data section.

Power Output (W)	
Number of cells on panel	
Area of each cell (cm ²)	
Total area of solar cells (m ²)	
Power per square meter (W/m ²)	
Power from the sun (W/m ²)	
Panel efficiency (%)	

Part II Effect of Wavelength

	Current (A)	Voltage (V)	Illumination (lux)	Power (W)
No filter				
Blue filter				
Red filter				
Green filter				

PROCESSING THE DATA

1. Calculate the average current, voltage and illumination values for Part I.
2. Calculate the power output using the equation

$$P = VI$$

Power = voltage \times current

3. Examine the open PV cell and record the number of cells on the panel.
4. Determine the area of one cell in cm^2 . Remember, the area of a rectangle is length \times width and the area of a triangle is $\frac{1}{2}$ base \times height. Draw a diagram of one cell and label any measurements that will help when calculating the area.
5. Calculate the total area of the cells in m^2 using the equation

$$\frac{\text{Number of cells on panel} \times \text{Area of one cell}}{10,000 \text{ cm}^2/\text{m}^2}$$

6. Determine the power per square meter output of the PV cell by dividing the power output by the total area of the cell.
 7. Determine the power per square meter output of the sun by dividing the average illumination value by 75 since $1 \text{ W}/\text{m}^2 = 75 \text{ lux}$.
 8. Calculate the efficiency of the PV cell using the equation
9. How does the efficiency of your PV cell compare to your predicted efficiency?
 10. What factors may contribute to the lack of efficiency of the PV cell?
 11. Calculate the power output for each of the trials in Part II using the equation

$$P = VI$$

Power = voltage \times current

12. Which of the colors had the highest power output? Which had the lowest output?
13. What can you conclude about the effect of wavelength on power output?
14. What types of conditions would contribute to an ideal location for PV cells used for electricity to heat a home?

EXTENSIONS

1. Determine the effect of the amount of light shining on a PV cell on the power output.
2. Determine the relationship between the angle of incidence of the light and the power output of a PV cell.
3. Determine whether efficiency depends on the load resistor.

Vernier Lab Safety Instructions Disclaimer

THIS IS AN EVALUATION COPY OF THE VERNIER STUDENT LAB.

This copy does not include:

- **Safety information**
- **Essential instructor background information**
- **Directions for preparing solutions**
- **Important tips for successfully doing these labs**

The complete *Agricultural Science with Vernier* lab manual includes 29 labs and essential teacher information. The full lab book is available for purchase at:

<http://www.vernier.com/cmat/awv.html>



Vernier Software & Technology

Vernier Software & Technology
13979 S.W. Millikan Way • Beaverton, OR 97005-2886
Toll Free (888) 837-6437 • (503) 277-2299 • FAX (503) 277-2440
info@vernier.com • www.vernier.com