

Bungee Jump Accelerations

In this experiment, you will investigate the accelerations that occur during a bungee jump. The graph below records the acceleration vs. time for an actual bungee jump, where the jumper jumped straight upward, then fell vertically downward. The positive direction on the graph is upward.

For about the first 2 seconds, the jumper stands on the platform in preparation for the jump. At this point the acceleration is 0 m/s^2 . In the next short period of time, the jumper dips downward then pushes upward, both accelerations showing up on the graph. Between about 2.5 seconds and 4.5 seconds, the jumper is freely falling and the acceleration is near -9.8 m/s^2 .

When all of the slack is out of the bungee cord, the acceleration begins to change. As the bungee cord stretches, it exerts an upward force on the jumper. Eventually the acceleration is upward although the jumper is still falling. A maximum positive acceleration corresponds to the bungee cord being extended to its maximum. One should be sufficient since, unlike an actual bungee jump, you will be able to control the rotation of your jumper.

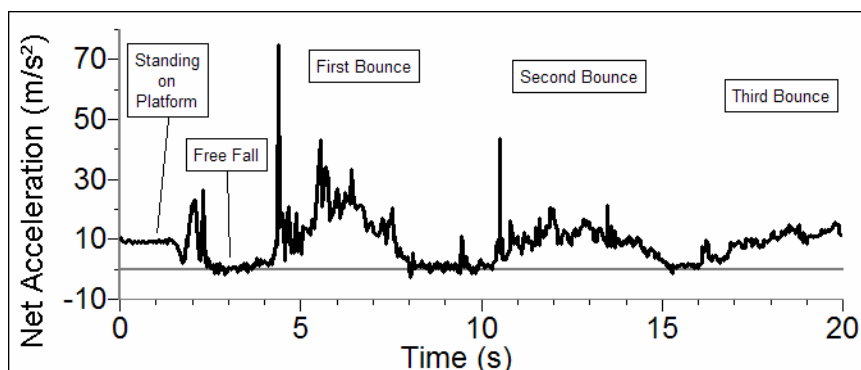

Figure 1

In your experiment, a block of wood or a toy doll will substitute for the jumper, and a rubber band will substitute for the bungee cord. An Accelerometer connected to the “jumper” will be used to monitor the accelerations.

OBJECTIVES

- Use an Accelerometer to analyze the motion of a bungee jumper from just prior to the jump through a few oscillations after the jump.
- Determine where in the motion the acceleration is at a maximum and at a minimum.
- Compare the laboratory jump with an actual bungee jump.

MATERIALS

- | | |
|--|--|
| TI-83 Plus or TI-84 Plus graphing calculator | bungee jumper (wooden block or small doll) |
| EasyData application | bungee cord (long, flexible rubber band) |
| data-collection interface | ring stand |
| Vernier Low-g Accelerometer | |

PRELIMINARY QUESTIONS

1. Consider the forces acting on the bungee jumper at the lowest point of the jump. Draw a free-body diagram indicating the forces acting on the jumper. Longer arrows should represent the force vectors with greater magnitude. Label the force vectors.
2. Study the graph of the acceleration during an actual bungee jump (Figure 1). On the graph, label the time corresponding to the lowest position during the jump.
3. What was the acceleration at that point? Was the direction of the acceleration up or down?
4. Label the time where the jumper reached the highest position during the first bounce.
5. What was the magnitude of the acceleration at that time? Was the direction of the acceleration up or down?
6. How long was the bungee cord used in the real bungee jump? Hint: Consider the time the jumper fell before the cord started to apply a force.

PROCEDURE

Part I The Jump—Step by Step

1. Turn on the calculator. Connect the Accelerometer, data-collection interface, and calculator. Attach a block of wood or small doll (your jumper) to the Accelerometer. The arrow on the Accelerometer should be pointing upward (toward the hook if using a block, or toward the feet of the doll).
2. Tie the rubber band to the hook on the wooden block or to the feet of the doll. Tie the other end of the rubber band to a rigid support, such as a large ring stand. Adjust the length of the cord so that the block or doll does not hit the floor when dropped.
3. Set up EasyData for data collection.
 - a. Start the EasyData application, if it is not already running.
 - b. Select **[File]** from the Main screen, and then select **New** to reset the application.
4. The Accelerometer must be zeroed so that it reads, only for the vertical direction, zero acceleration when at rest and -9.8 m/s^2 when in free fall.
 - a. Select **[Setup]** from the Main screen, and then select **Zero...**
 - b. Rest the bungee jumper stationary on the table, with the Accelerometer arrow pointing directly upward.
 - c. When the accelerometer reading is stable, select **[Zero]**.
5. Make sure your jumper is oriented properly (arrow pointed up). Select **[Start]** to begin collecting data. Hold the jumper motionless for one second, and then release it. Catch the jumper while the cord is still slack.
6. When data collection has finished, your graph will be displayed. Trace across the graph with the cursor keys. For the first second or so, the acceleration should be near zero, since you zeroed the sensor in Step 4. This value represents the acceleration of the jumper prior to jumping.

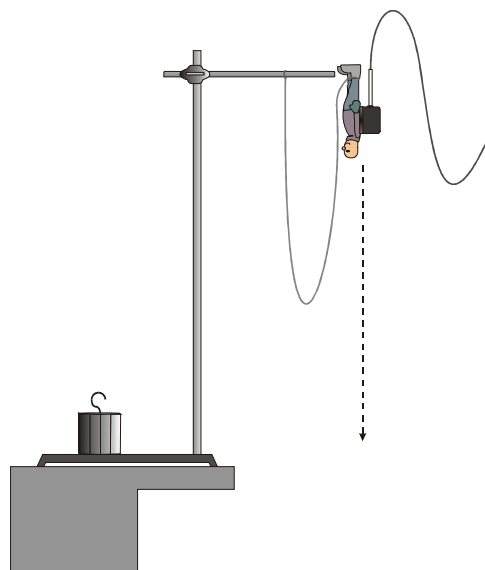

Figure 2

7. Trace farther to the right on your graph and read the acceleration during the fall. It should be close to -9.8 m/s^2 . Ignore any data collected after you caught the jumper.
8. Now collect some data corresponding to the bounces after the free fall portion of the jump.
 - a. Let the jumper hang from the bungee cord.
 - b. Select **(Main)** to return to the Main screen.
 - c. Pull the jumper down 5 cm and hold it stationary.
 - d. Select **(Start)**, then **(OK)** to overwrite the latest run and begin data collection.
 - e. Wait about one second, and then release the jumper, creating an up-and-down oscillation similar to a mass suspended from a spring.
 - f. After data collection has finished, your graph is displayed. Determine the point in the motion where acceleration is both positive in direction and has a maximum magnitude. Does this occur when the jumper is at the bottom, middle, or top of the oscillation?

Part II A Complete Jump

9. Lift the bungee jumper to the height of the ring stand, as shown in Figure 2. The bungee cord should be hanging to the side and the Accelerometer cable should be clear of the jump path. Make sure that the Accelerometer arrow is pointing upward. The connection point between the bungee cord and the jumper should also be pointing upward, so that the jumper does not turn over during the jump.
 - a. Select **(Main)** to return to the Main screen.
 - b. Select **(Start)**, then **(OK)** to overwrite the latest run and begin data collection.
 - c. Wait 1 second and release the bungee jumper so that it falls straight down with a minimum of rotation. Let the jumper bounce a few times. Be sure that the Accelerometer cable still has some slack when the jumper reaches the lowest point.
10. Repeat the measurement until you have a satisfactory set of data. A successful run should include a minimum of rotation, a section of free fall before the cord starts to pull on the jumper, and a few bounces, with at least the first bounce high enough to cause the cord to again go slack. The acceleration vs. time graph for the laboratory jump should show features similar to the graph of the real bungee jump. Print or sketch your final graph.

DATA TABLE

Time (s)	Acceleration (m/s ²)	Direction of motion (up, down, or rest)

ANALYSIS

1. Trace across your acceleration *vs.* time graph using the cursor keys. Determine the acceleration at eight different points on the graph, choosing points during the initial rest, free fall, when the cord is taut, and several bounces. Record the values in your data table. Indicate the direction of the motion using *up*, *down*, or *at rest*.
2. Perform the same analysis on your bungee jump as was done on the real bungee jump in the Preliminary Questions section.
3. How well does the laboratory jump compare with the real jump? Discuss the similarities and differences.
4. How could you improve the correlation between the lab jump and the real jump?

EXTENSIONS

1. Place a Motion Detector on the floor during a jump. Examine the Motion Detector data (distance *vs.* time and velocity *vs.* time graphs) of the jump. How do these data compare to the Accelerometer data? Which sensor do you think is a better tool for the analysis of the jump? Explain.
2. If a video camera is available, videotape the laboratory bungee jump or a real bungee jump. View the videotape and match the Accelerometer graph with the video of the jump.
3. Repeat the experiment with a jumper of different mass. What are the similarities and differences between the two sets of data? Discuss some methods that might be used by operators of commercial bungee jumps to assure the safety of jumpers of different weights.
4. Connect the bungee cord to a Force Sensor to examine the cord tension during the jump.
5. Use reference books or the Internet to learn the accelerations experienced by the Shuttle astronauts during takeoff and re-entry. How do the accelerations experienced by the astronauts compare to the maximum acceleration experienced by a bungee jumper?

TEACHER INFORMATION

Bungee Jump Accelerations

1. The student pages with complete instructions for data collection using LabQuest App, Logger *Pro* (computers), EasyData or DataMate (calculators), and DataPro (Palm handhelds) can be found on the CD that accompanies this book. See *Appendix A* for more information.
2. The rubber bungee cord should be very flexible. When the bungee jumper reaches the bottom of the jump, the rubber band should still have some stretch left. You can create a long bungee cord by connecting a number of smaller rubber bands. The rubber band from a paddle-ball toy works very well. A paddle-ball rubber band, with an unstretched length of 1 m, was used for the sample data. Its length at the bottom of the bounce was 2.5 m.
3. A small doll with a mass of 84 g was used for the sample data.
4. Some students may try to analyze the acceleration graph as if it were a record of position. This lab will be a challenge to a student with a limited concept of acceleration. Remember that acceleration is proportional to the net force on the jumper, and that the total force is largest and upward when the bungee cord is stretched to the maximum extent.
5. Be sure to use a sturdy ring stand.
6. The bungee jump data displayed in this experiment was taken in July 1997 by Marvin Giesting (Connersville High School, Connersville, In), a physics teacher attending Project PHYSLab in Portland, Oregon. Marvin actually had our Three-Axis Accelerometer (3D-DIN) in a CBL case. This is equivalent to three Low-g Accelerometers mounted at right angles, in one package. The CBL case was in a backpack worn during the jump. For this real jump, we calculated and graphed the magnitude of the vector sum of the three accelerations. In the laboratory jump, the orientation of the jumper can be controlled and the Three-Axis Accelerometer is not needed.
7. If a larger mass is desired to approximate a better actual bungee jump, a 5-lb sack of rice, sugar, flour, or beans could be used. Tape the Accelerometer to the side of the “jumper.” For a bungee cord, 1/4” and 3/8” bungee cord is available from most hardware stores. A very sturdy hook must be used in this case.

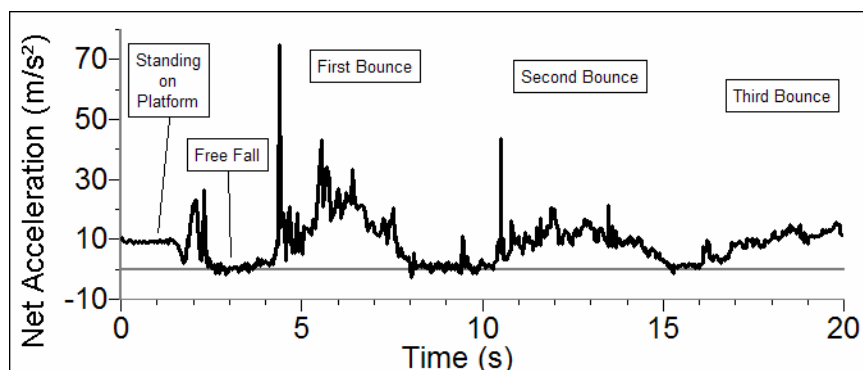

This jump was made by Marvin Giesting (July 1997, Portland, Oregon)

SAMPLE RESULTS

	Time (s)	Acceleration (m/s ²)	Direction of motion (up, down, rest)
1	0.50	xxxx	xxxx
2	0.92	xxxx	xxxx
3	1.16	xxxx	xxxx
4	1.50	xxxx	xxxx
5	1.90	xxxx	xxxx
6	2.36	xxxx	xxxx
7	2.90	xxxx	xxxx

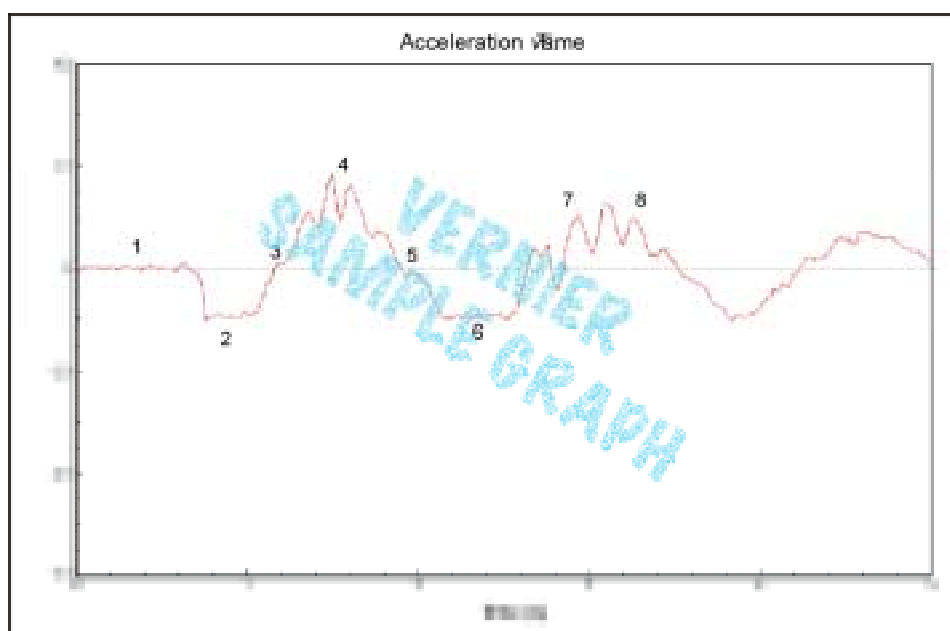

ANSWERS TO PRELIMINARY QUESTIONS

ANSWERS TO PROCEDURE QUESTIONS

ANSWERS TO ANALYSIS QUESTIONS

Answers have been removed from the online versions of Vernier curriculum material in order to prevent inappropriate student use. Graphs and data tables have also been obscured. Full answers and sample data are available in the print versions of these labs.